

JVC

SERVICE MANUAL

COMPACT VHS CAMCORDER

GR-FX101EK

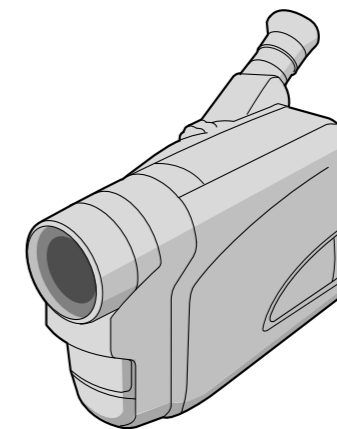

Compact VHS



Regarding service information other than these sections, refer to the GR-FX11EK service manual (No. 86547). Also, be sure to note important safety precautions provided in the service manual.

SPECIFICATIONS *(The specifications shown pertain specifically to the model GR-FX101EK)*

Camcorder	
General	
Format	: VHS PAL standard
Power source	: DC 6.0 V
Power consumption	: 5.2 W
Signal system	: PAL-type
Video recording system	
Luminance	: FM recording
Colour	: Converted sub-carrier direct recording Conforms to VHS standard
Cassette	: cassette
Tape speed	
SP	: 23.39 mm/sec.
LP	: 11.70 mm/sec.
Recording time (max.)	
SP	: 60 minutes
LP	: 120 minutes (with EC-60 cassette)
Operating temperature	
Operating temperature	: 0°C to 40°C
Operating humidity	: 35% to 80%
Storage temperature	: -20°C to 50°C
Weight	: Approx. 830 g
Dimensions (W x H x D)	
Dimensions (W x H x D)	: 198 mm x 119 mm x 91 mm (with the viewfinder fully tilted downward)
Pickup Lens	
Pickup Lens	: 1/4" format CCD F1.6, f = 3.9 to 62.4 mm, 16:1 power zoom lens with auto iris and macro control, filter diameter 40.5 mm
Viewfinder	
Viewfinder	: Electronic viewfinder with 0.5" black/white CRT
White balance adjustment	
White balance adjustment	: Auto/Manual adjustment
Connectors	
JLIP	
JLIP	: ø3.5 mm, 4-pole, mini-head jack (compatible with RC-5325 plug)
Video	
Video	: 1 V(p-p), 75 Ω unbalanced, analogue output (via Video output connector)
Audio	
Audio	: 300 mV (rms), 1 kΩ analogue output (via Audio output connector)
AC Power Adapter/Charger AA-V16EK	
Power requirement	: AC 110 V to 240 V~, 50 Hz/60 Hz
Power consumption	
Power consumption	: 23 W
Output	
Charge	: DC 8.5 V , 1.3 A
VTR	: DC 6.3 V , 1.8 A
Charging system	
Charging system	: Constant current, peak detection, timer controlled
Dimensions (W x H x D)	
Dimensions (W x H x D)	: 125 mm x 42 mm x 68 mm
Weight	
Weight	: Approx. 330 g
Optional Accessories	
<ul style="list-style-type: none">• Battery Packs BN-V12U, BN-V20U, BN-V856U• Car Battery Charger BH-V3E• Compact VHS () Cassettes EC-60/45/30• Remote Control Unit RM-V700U• Active Carrying Bag CB-V7U• Cassette Adapter C-P7U	
Some accessories are not available in some areas. Please consult your nearest JVC dealer for details on accessories and their availability.	
<i>Specifications shown are for SP mode unless otherwise indicated.</i>	
<i>E & O.E. Design and specifications subject to change without notice.</i>	

JVC

VICTOR COMPANY OF JAPAN, LIMITED
VIDEO DIVISION

S40894

TABLE OF CONTENTS

DIFFERENT TABLE		1 to 2
4. CHARTS AND DIAGRAMS		
4.1 DSP SCHEMATIC DIAGRAM		4-1
4.2 MAIN CIRCUIT BOARD		4-3
5. PARTS LIST		
5.1 PACKING AND ACCESSORY ASSEMBLY <M1>		5-1

The following table indicate main different points between models GR-FX11EK and GR-FX101EK.

ITEM	MODEL	GR-FX11EK	GR-FX101EK
BODY COLOR		Black	Light Gold

The following table indicate different parts number between models GR-FX11EK and GR-FX101EK.

PACKING AND ACCESSORY ASSEMBLY <M1>

REF NO.	ITEM	MODEL	GR-FX11EK	GR-FX101EK
2	PACKING CASE		LY31561-023A	LY31561-065A
△ 5	IB (EN)		LYT0495-001A	LYT0631-001A
6	Q.CARD (JUK)		* –	LYT0194-001A

FINAL ASSEMBLY <M2>

REF NO.	ITEM	MODEL	GR-FX11EK	GR-FX101EK
101K	HOLDER(LITHIUM)		* LY30888-001B	LY30888-002A
106	FRONT COVER ASSY		LY10124-047A	LY10124-056A
106R	COVER (LIGHT)		LY30934-001A	LY30934-013A
△ 107	CASS.COVER ASSY		LY10189-005A	LY10189-009A
110	TOP COVER		LY10129-087A	LY10129-0C3A
113	OPERATION UNIT		LY10120-044A	LY10120-058A
152	CASSETTE HOUSING ASSY		* YQ31752J-31	YQ31752J-34

OPTICAL BLOCK SECTION

REF NO.	ITEM	MODEL	GR-FX11EK	GR-FX101EK
255	OPTICAL LPF		* LY41755-001A	–

Note: Mark – is not used. Mark * reference model was also changed.

MAIN BOARD ASSEMBLY <01>

REF NO.	ITEM	MODEL	GR-FX11EK	GR-FX101EK
PW	MAIN BOARD ASSY		* YB10257PJ-03	YB10293PJ
IC4001	IC		* JCY0115	JCY0099
Q4006	PAIR TRANSISTOR		* PUMT1	PUMX1
R4007	CMF RESISTOR		* NRVA63D-163X	NRVA63D-153X
R4010	MG RESISTOR/CMF RESISTOR		* NRSA63J-0R0X	NRVA63D-103X
R4011	MG RESISTOR		* NRSA63J-0R0X	NRSA63J-272X
R4012 R4013	MG RESISTOR		* NRSA63J-332X	NRSA63J-272X
R4028 R4038	MG RESISTOR		* -	NRSA63J-561X
R4052 R4053	MG RESISTOR		* -	NRSA63J-101X
R4065	MG RESISTOR		* NRSA63J-201X	-
R4066	MG RESISTOR		* NRSA63J-182X	-
R4067	MG RESISTOR		* NRSA63J-201X	-
R4068	MG RESISTOR		* NRSA63J-182X	-
R4070	MG RESISTOR		* NRSA63J-683X	-
C4017	CAPACITOR		* NCB31CK-104X	-
C4041	CAPACITOR		* NCF31EZ-104X	-
C4043 C4044	CAPACITOR		* NCB21AK-105X	-
X3001	CRYSTAL RESONATOR		* QAX0518-001	QAX0628-001

Note: Mark - is not used. Mark * reference model was also changed.